



# The CO<sub>2</sub> WALL-STAT™ Indoor Air Quality Sensor Model 6289W

## Features:

### The Ideal IAQ CO<sub>2</sub> Sensor with long term low maintenance operation

- No moving parts infrared sensor
- Convenient **24 VAC** or DC operation
- Smallest, most compact size available
- Excellent long term stability
- **ECONO-CAL™** Calibration Gas Kit
- No pump or particulate filters required
- Diffusion gas sampling
- Adjustable set point SPDT control relay
- **Linear** 0-5 VDC and 4-20 mA outputs
- **LED's** indicate **power** on and **relay activation**
- Non-Dispersive Infra-Red (**NDIR**) technology
- Calibration gas port easily accessible
- Optional digital LCD display 0-1999 ppm
- **Test Connector** installed as an **Option**

## Model 6289W CO<sub>2</sub> WALL-STAT™

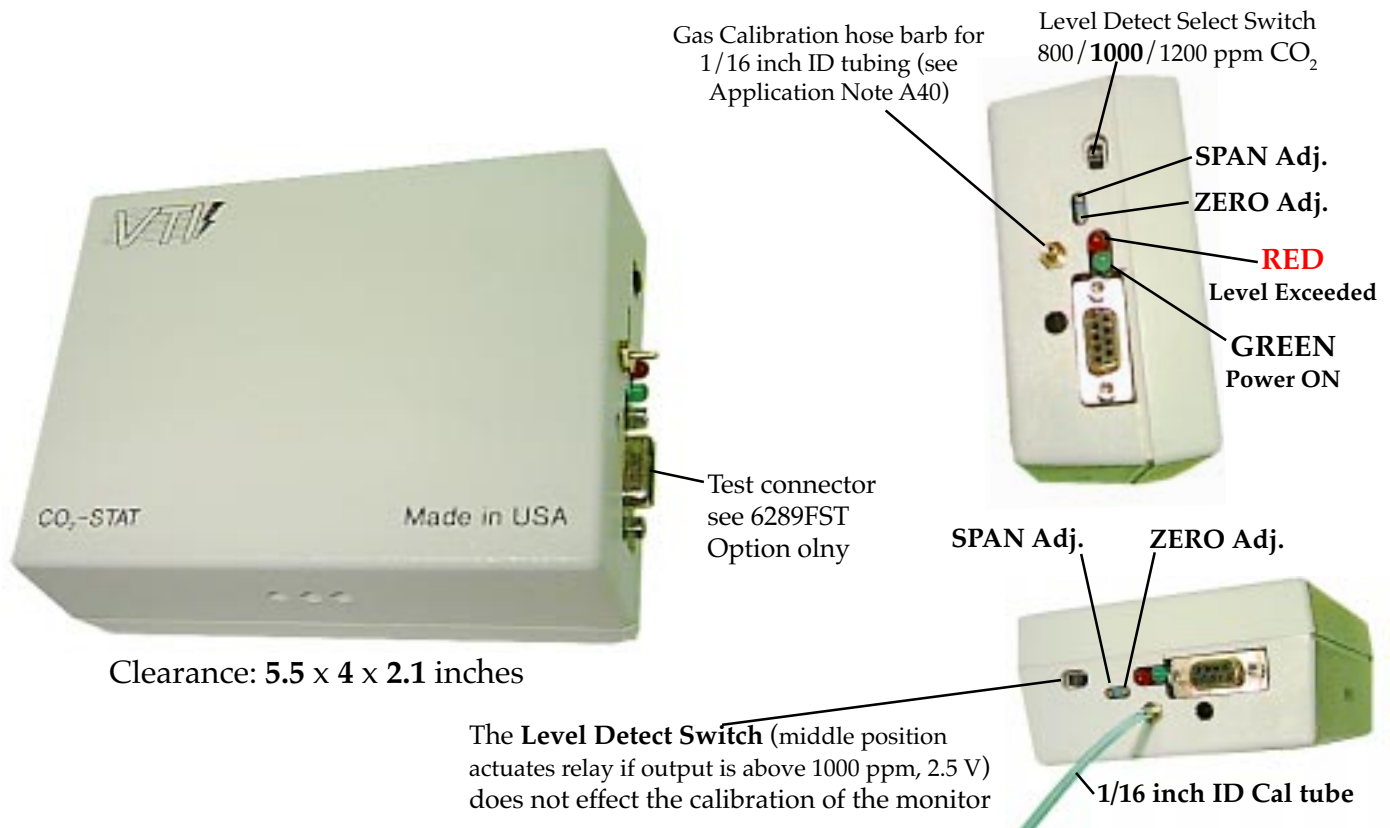

## Application:

### HVAC

- Hospitals
- Offices
- Schools
- Theaters
- Indoor Sports Arenas

The VALTRONICS Model 6289W is a non-dispersive infrared carbon dioxide monitor for use as an indoor air quality sensor. It produces a control signal proportional to carbon dioxide concentration. This control signal is then used to provide remote control of the outdoor air dampers, thereby controlling the fresh air intake or varying the ventilation rates while still maintaining safe indoor air quality.



# The CO<sub>2</sub> WALL-STAT™ Indoor Air Quality Sensor Model 6289W 0.2% CO<sub>2</sub>

## Description:

The Model 6289W consists of a patented no moving parts infrared CO<sub>2</sub> monitor in a protective plastic case which allows free passage of air to the sensing cell inside. This sensing cell consists of a non-dispersive infrared carbon dioxide optical diffusion gas cell. It uses a pulsed infrared source and has no free air optical path. This configuration is designed for use as a wall mounted CO<sub>2</sub> sensor in HVAC control systems of all sizes from a single sensor up to a complete computer controlled multiple point system.

The 6289W has linear signal outputs of 0-5 Volts DC and a 4-20 mA current loop (no external power is required in the current loop) to connect to a computer or controller. Most building management systems and direct digital control systems are capable of interfacing with the Model 6289W.

## Specifications: 6289W 0.2% CO<sub>2</sub> WALL-STAT™

- Method: ..... N.D. I. R. (Non-dispersive Infra-red) Diffusion type gas sampling
- Gas: ..... Carbon dioxide (CO<sub>2</sub>)
- Range: ..... 0-2,000 ppm (0.2%) CO<sub>2</sub>
- Accuracy: ..... ± 5% of reading from 1000 to 2000 ppm (±50 ppm at 1000 ppm and below)
- Repeatability: ..... ± 1% of full scale (challenge with same gas sample and assure zero)
- External Power Source: ..... 24 Volts A.C. or D.C. @ 0.5 amp. max. (20.0 to 30.0 VAC RMS or 22 to 30 VDC)  
See Instruction Manual for wiring, test connector features, and theory of operation
- Power Consumption: ..... 4.25 watts typical @ 24 V.A.C. (6 watts maximum)
- Adjustable set point,  
factory set at 1000 ppm: ..... SPDT Control relay (SPDT N.C. , N.O. 3Amp @250 VAC or 30 VDC)
- Set point is slide switch: ..... (3 position) selectable: 800, 1000, or 1200 ppm or  
internally jumper selected to be continuously variable
- Output Signals:
  - Voltage: ..... 0 to 5 volt = 0 to 2000 ppm ( linear scale data attached)
  - Current Loop: ..... 4 to 20 mA = 0 to 2000 ppm ( linear scale data attached) no external power
  - 9 pin "D" **Test Connector**: ..... Removed Aug 2000 - **installed as an option only.**
- Zero Drift at Constant Temperature: ..... Less than 100 ppm per year (random not cumulative)
- Zero Noise at Constant Temperature: ..... Less than 20 ppm peak to peak measured during any 20 second period
- Zero Drift due to Ambient Temperature: Less than 10 ppm per degree Centigrade
- Operating Temperature Range: .. 0 to 50°C (32° to 122°F) see **Application Note A12**
- Storage Temperature Range: ..... -40 to +70°C (-40 to +158°F)
- Operating Humidity Range ..... 5 to 95% RH non-condensing
- Weight: ..... Less than 0.5 pound (<0.23 kilogram)
- External Dimensions: ..... 4" x 5" x 2" (10.16 cm, x 12.7 cm, x 5.08 cm)



PPM CO <sub>2</sub>	Output V	Max	Min	4-20 mA	Max	Min
0	0.000	0.125	-0.125	4.00	4.4	3.6
50	0.125	0.250	0.000	4.40	4.80	4.00
100	0.250	0.375	0.125	4.80	5.20	4.40
150	0.375	0.500	0.250	5.20	5.60	4.80
200	0.500	0.625	0.375	5.60	6.00	5.20
250	0.625	0.750	0.500	6.00	6.40	5.60
300	0.750	0.875	0.625	6.40	6.80	6.00
350	0.875	1.000	0.750	6.80	7.20	6.40
400	1.000	1.125	0.875	7.20	7.60	6.80
450	1.125	1.250	1.000	7.60	8.00	7.20
500	1.250	1.375	1.125	8.00	8.40	7.60
550	1.375	1.500	1.250	8.40	8.80	8.00
600	1.500	1.625	1.375	8.80	9.20	8.40
650	1.625	1.750	1.500	9.20	9.60	8.80
700	1.750	1.875	1.625	9.60	10.00	9.20
750	1.875	2.000	1.750	10.00	10.40	9.60
800	2.000	2.125	1.875	10.40	10.80	10.00
850	2.125	2.250	2.000	10.80	11.20	10.40
900	2.250	2.375	2.125	11.20	11.60	10.80
950	2.375	2.500	2.250	11.60	12.00	11.20
1000	2.500	2.625	2.375	12.00	12.40	11.60
1050	2.625	2.756	2.494	12.40	12.82	11.98
1100	2.750	2.888	2.613	12.80	13.24	12.36
1150	2.875	3.019	2.731	13.20	13.66	12.74
1200	3.000	3.150	2.850	13.60	14.08	13.12
1250	3.125	3.281	2.969	14.00	14.50	13.50
1300	3.250	3.413	3.088	14.40	14.92	13.88
1350	3.375	3.544	3.206	14.80	15.34	14.26
1400	3.500	3.675	3.325	15.20	15.76	14.64
1450	3.625	3.806	3.444	15.60	16.18	15.02
1500	3.750	3.938	3.563	16.00	16.60	15.40
1550	3.875	4.069	3.681	16.40	17.02	15.78
1600	4.000	4.200	3.800	16.80	17.44	16.16
1650	4.125	4.331	3.919	17.20	17.86	16.54
1700	4.250	4.463	4.038	17.60	18.28	16.92
1750	4.375	4.594	4.156	18.00	18.70	17.30
1800	4.500	4.725	4.275	18.40	19.12	17.68
1850	4.625	4.856	4.394	18.80	19.54	18.06
1900	4.750	4.988	4.513	19.20	19.96	18.44
1950	4.875	5.119	4.631	19.60	20.38	18.82
2000	5.000	5.250	4.750	20.00	20.80	19.20

9 pin "D" Test Connector: Removed Aug 2000 - installed as an option only.



**MOUNTING on the wall and wiring:**

Remove the back cover of the unit using a broad bladed flat screwdriver to pry the cover near the two black press fit type studs .

Locate the unit on a flat mounting surface of a wall near a return air grill. The area should be at least 5.5" square. Drill two 0.093 inch diameter ( $\frac{3}{32}$ ) holes using the DETAIL #1 as a guide. Mount the enclosure using two #6 screws and flat washers through the 1/8 inch diameter holes on either side of the 1/2 inch diameter cable access hole.

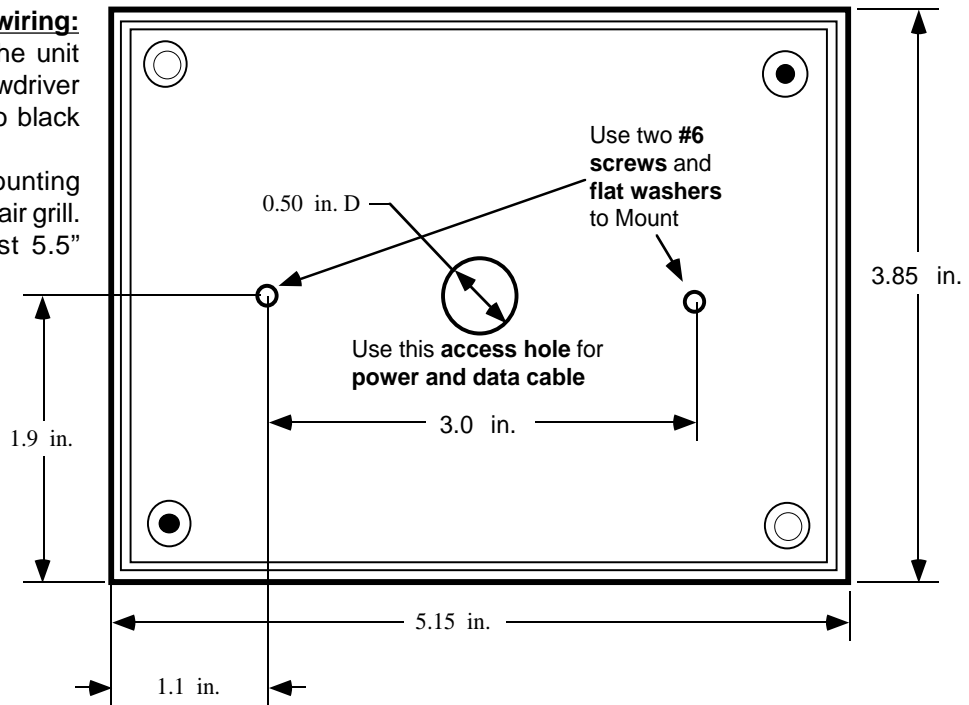

Using 22 AWG to 14 AWG (20 AWG typical) wire connected to terminal block TB1 (see diagram below), pull the power, signal, and relay contact wires (you only need to wire the functions that you want to use) through the 0.50 inch access hole.

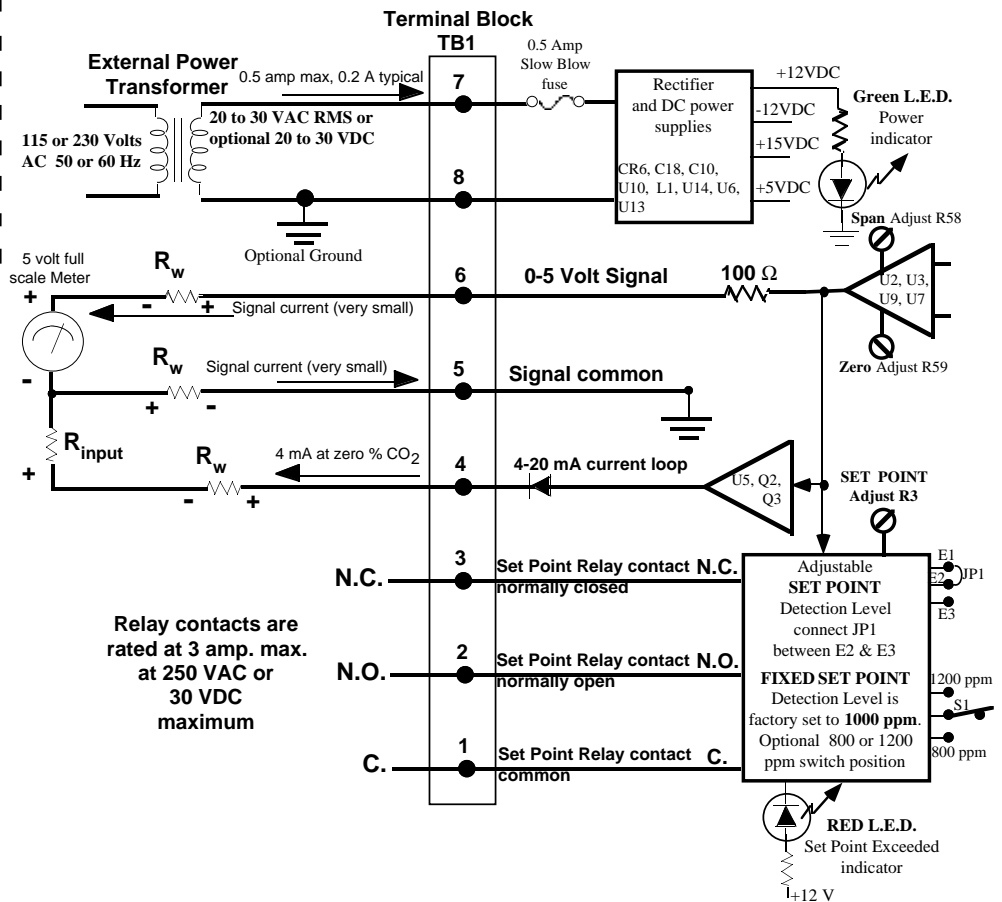
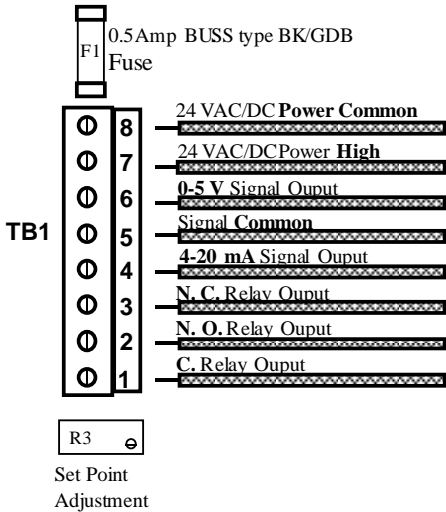

**Caution: DO NOT** connect external power in the 4-20 mA current loop

Relay contacts are rated at 3 amp. max. at 250 VAC or 30 VDC maximum