

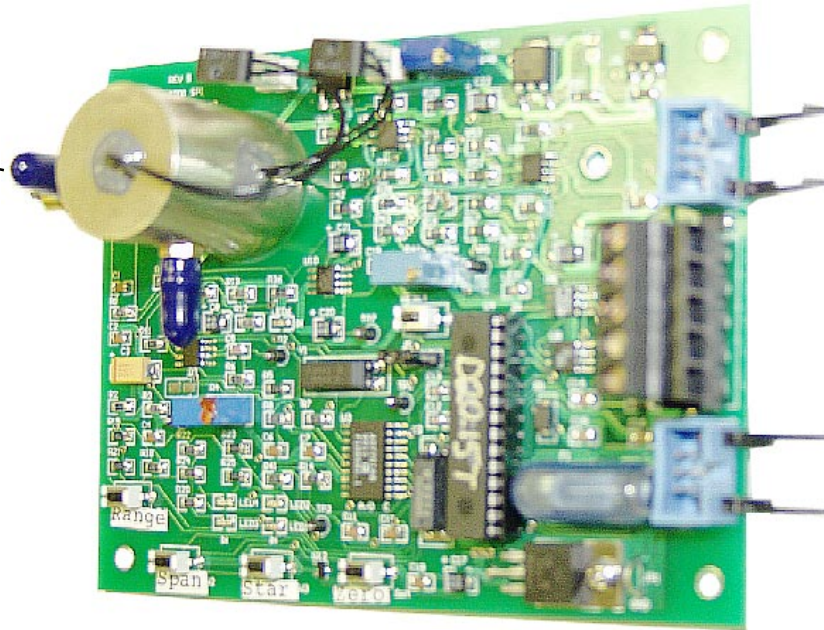

Version D20.15T Model 2208 Digital Flow Thru CO₂ Sensor

User may set the **RANGE** for analog outputs from **3** to **20%** full scale

Flow through gas cell with adjustable flow valve for flow between 0.3 to 0.9 liter per min. Hose barbs for 1/8 inch ID tubing. See App Note A67 for gas conditioning.



- J2** (16 bit serial) see page 2
- J1**
 - 5.** 4-20 mA out
 - 4.** Sig common
 - 3.** 0-1 Volt out
 - 2.** Ground
 - 1.** +12 VDC
- J3** (remote cal) see page 2

Full scale is **user selectable RANGE** from **3%** to **20%** CO₂ (see page 4). If you use the 16 bit serial output you will not have to worry about setting the **RANGE** because you will get **16 bit resolution** over the whole 0 to 20% scale (see Application Note A61). Decimal 500 = implied **5.00%** gas = binary 0000 0001 1111 0100 Divide decimal value by 100 to equal % gas reading

The mounting configuration is identical to the **old Model 2008SDH** where there are four (4) **0.140"** dia holes on **3.19** by **4.5** inch centers. The board has clearance dimensions of **3.7** by **5.0** inches with **1.8 inch vertical** clearance and an **additional 0.7 inch** clearance for the connector latches shown for J2 (Serial Digital SPI) and J3 the remote calibration switch connector.

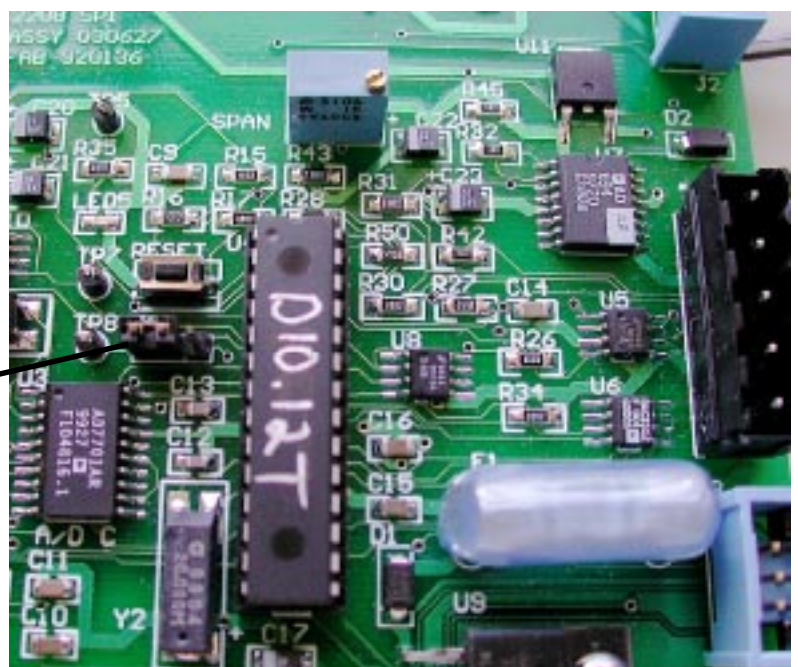

MASTER / SLAVE jumper JP2 shown in **MASTER** Mode position. When jumper is moved to two pins near to U4 (PIC μ processor) and the **RESET** switch is pressed it will go into **SLAVE** Mode (see application Notes A61 & A59).

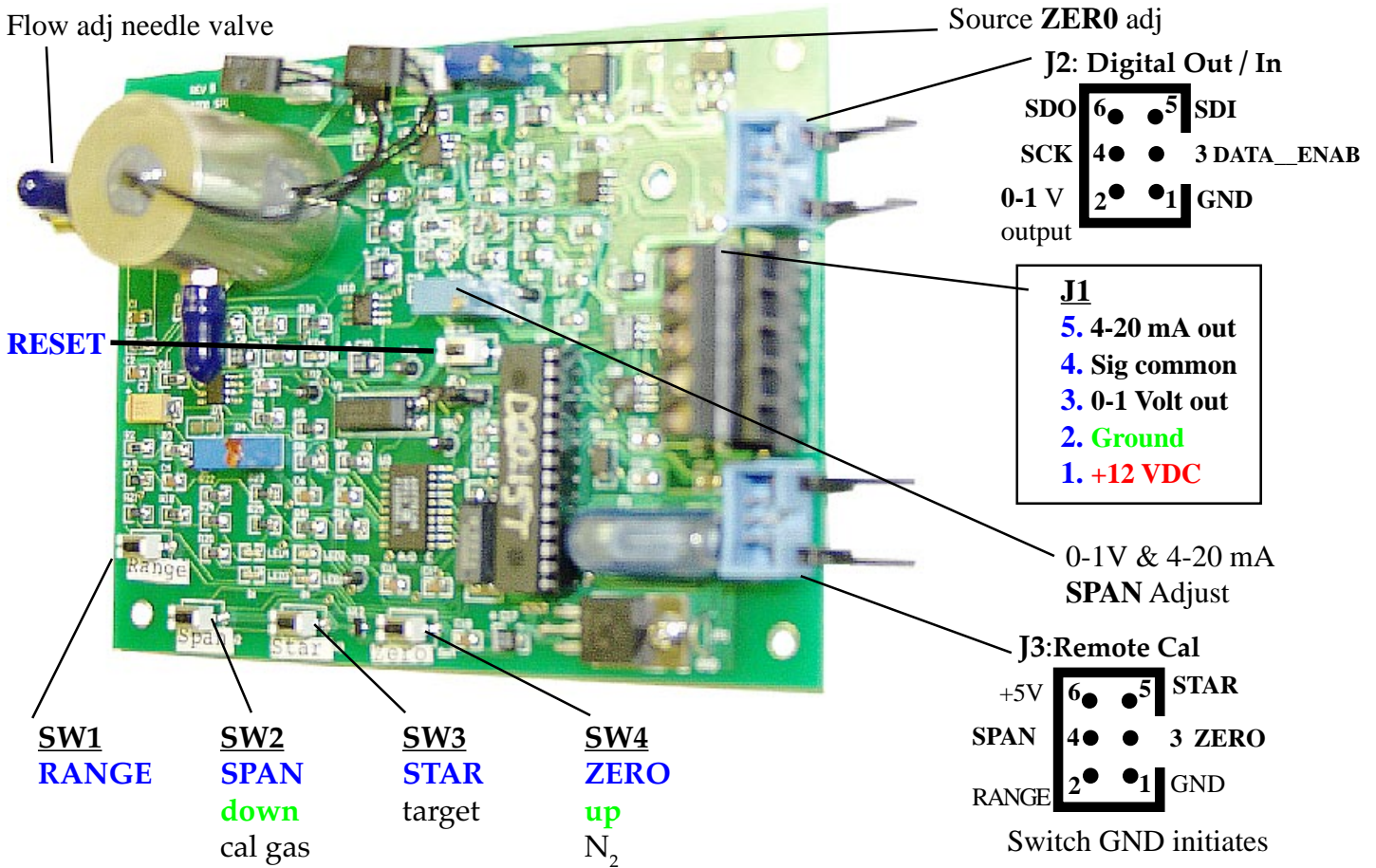

Method: **NDIR** with Digital Signal processing and temperature compensation

Gas: Carbon Dioxide (**CO₂**), Sample flow rate between 0.3 to 0.9 liter per minute

Range: **User adjustable** from **3% to 20% CO₂**

Input Power **+12 VDC** (@ 0.25 amp max., 0.135 amp typ, 16.0 volts max, 11.0 volts min)

Accuracy: ±0.5% of Mid-scale from 0 to mid-scale & ±5% of reading from mid to full scale

Resolution / Repeatability : **±1% of RANGE** (challenge with same gas sample multiple times & assure zero)

Stability: Less than during a 20 second period at constant temp. & pressure

Output Signals: 16 bit serial & Linear **0-1 volt** & **4-20 mA** output signals: see pg 3

..... See Note **A61** for **16 bit serial digital** output & **A59** for input control

Optional **RS232 Test Board** PCB for terminal com. with any PC , see **Application Note A66**

LED Indicators: **IR** Source **ON/OFF** Indicator, **Power ON** indicator, **4 Cal Switch** Indicators

Input Signal: Digital **SPI** input for calibration and diagnostic modes. See page 2

Calibration Switches: SW1(**Range**), SW2(**Span**), SW3(**Span Target**), SW4(**Zero**) remote via **J3**

Operating Temperature Range: 0 to 50°C (32° to 122°F) see **Application Note A12**

Caution: Avoid Dew Point temperature of gas sample to avoid condensation

..... Use a **Hydrophobic filter** in front of gas inlet hose barb.

Ambient Relative Humidity: 0 to 95% RH non-condensing: see **Application Note A30**

Storage Temperature range:- -40 to +70°C (-40 to +158°F)

Weight: Less than 0.4 pound

Clearance Dimensions: PCB Card: **5 inch x 3.7 inch x 1.8 inch** see page 1 for mounting

With **RANGE** set to **20.0%** CO₂. See page 4 for an example of a **10% RANGE**. Press **RANGE** switch (SW1) while measuring the 0 to 1 volt output for 1.00 volt = 20%, 0.5 volt = 10.0%, etc (see chart below).

Gas in %	Output in volts	±5% of reading		4-20 mA output	±5% of reading		4-20 mA across 250Ω in volts
		Max.	Min.		Max.	Min.	
0.00	0.000	0.025	-0.025	4.00	4.40	3.60	1.000
0.40	0.020	0.045	-0.005	4.32	4.72	3.92	1.080
0.80	0.040	0.065	0.015	4.64	5.04	4.24	1.160
1.20	0.060	0.085	0.035	4.96	5.36	4.56	1.240
1.60	0.080	0.105	0.055	5.28	5.68	4.88	1.320
2.00	0.100	0.125	0.075	5.60	6.00	5.20	1.400
2.40	0.120	0.145	0.095	5.92	6.32	5.52	1.480
2.80	0.140	0.165	0.115	6.24	6.64	5.84	1.560
3.20	0.160	0.185	0.135	6.56	6.96	6.16	1.640
3.60	0.180	0.205	0.155	6.88	7.28	6.48	1.720
4.00	0.200	0.225	0.175	7.20	7.60	6.80	1.800
4.40	0.220	0.245	0.195	7.52	7.92	7.12	1.880
4.80	0.240	0.265	0.215	7.84	8.24	7.44	1.960
5.20	0.260	0.285	0.235	8.16	8.56	7.76	2.040
5.60	0.280	0.305	0.255	8.48	8.88	8.08	2.120
6.00	0.300	0.325	0.275	8.80	9.20	8.40	2.200
6.40	0.320	0.345	0.295	9.12	9.52	8.72	2.280
6.80	0.340	0.365	0.315	9.44	9.84	9.04	2.360
7.20	0.360	0.385	0.335	9.76	10.16	9.36	2.440
7.60	0.380	0.405	0.355	10.08	10.48	9.68	2.520
8.00	0.400	0.425	0.375	10.40	10.80	10.00	2.600
8.40	0.420	0.445	0.395	10.72	11.12	10.32	2.680
8.80	0.440	0.465	0.415	11.04	11.44	10.64	2.760
9.20	0.460	0.485	0.435	11.36	11.76	10.96	2.840
9.60	0.480	0.505	0.455	11.68	12.08	11.28	2.920
10.00	0.500	0.525	0.475	12.00	12.40	11.60	3.000
10.40	0.520	0.546	0.494	12.32	12.74	11.90	3.080
10.80	0.540	0.567	0.513	12.64	13.07	12.21	3.160
11.20	0.560	0.588	0.532	12.96	13.41	12.51	3.240
11.60	0.580	0.609	0.551	13.28	13.74	12.82	3.320
12.00	0.600	0.630	0.570	13.60	14.08	13.12	3.400
12.40	0.620	0.651	0.589	13.92	14.42	13.42	3.480
12.80	0.640	0.672	0.608	14.24	14.75	13.73	3.560
13.20	0.660	0.693	0.627	14.56	15.09	14.03	3.640
13.60	0.680	0.714	0.646	14.88	15.42	14.34	3.720
14.00	0.700	0.735	0.665	15.20	15.76	14.64	3.800
14.40	0.720	0.756	0.684	15.52	16.10	14.94	3.880
14.80	0.740	0.777	0.703	15.84	16.43	15.25	3.960
15.20	0.760	0.798	0.722	16.16	16.77	15.55	4.040
15.60	0.780	0.819	0.741	16.48	17.10	15.86	4.120
16.00	0.800	0.840	0.760	16.80	17.44	16.16	4.200
16.40	0.820	0.861	0.779	17.12	17.78	16.46	4.280
16.80	0.840	0.882	0.798	17.44	18.11	16.77	4.360
17.20	0.860	0.903	0.817	17.76	18.45	17.07	4.440
17.60	0.880	0.924	0.836	18.08	18.78	17.38	4.520
18.00	0.900	0.945	0.855	18.40	19.12	17.68	4.600
18.40	0.920	0.966	0.874	18.72	19.46	17.98	4.680
18.80	0.940	0.987	0.893	19.04	19.79	18.29	4.760
19.20	0.960	1.008	0.912	19.36	20.13	18.59	4.840
19.60	0.980	1.029	0.931	19.68	20.46	18.90	4.920
20.00	1.000	1.050	0.950	20.00	20.80	19.20	5.000

Accuracy = ±5% of reading from 10% CO₂ to 20% and ±0.5% CO₂ from 0 to 10% CO₂

Gas **Calibration** (ZERO & SPAN) every 6 months at a minimum, ZERO Calibration more often for best results. The best way to gas calibrate is to use the RS-232 Test Board (**Application Note A66**). This will give you the best visibility on the sensor's operation including an ability to compare critical parameters that were stored during the previous calibration. If you have any question about the stability of the sensor, comparing the stored VZ (detector's response to zero gas) & TZ (zero temperature °C) of the previous cal to the present Volts reading with ZERO gas (keyboard 1,1 command) will give you a clear indication of stability. Keep in mind that the VZ and Volts reading (Actually a Ratio reading) are effected by temperature. The ZTC figure that was stored during factory calibration shows how much the VZ will be effected by temperature. If the ZTC is shown as 4.46 then the Volts response to ZERO gas will increase 4.46 for every °C increase in temperature from the ZERO calibration temperature. If you do not have the RS-232 Test Board, you may measure the 0-1 volt output and use the ZERO switch (either on board or remote via J3). Flow ZERO gas through the cell at about 500 ml/min and look for a stable reading on the 0-1 volt output. Press and hold the **ZERO** switch (SW4) for 2 seconds. LED4 will flash. If the ZERO routine is OK, all the LEDs (1 thru 4) will flash. The 0-1 volt output will snap to 0.00 volt. To SPAN calibrate make sure the **STAR** value matches the certified span gas concentration you are using, i.e. STAR = 5.00 (0.25 volt on the 0-1V output when you press the STAR switch (SW3) for 5.00% CQ₂ span gas. Flow 5.00% CO₂ span gas at about 500 ml/min and look for a stable reading. Press and hold the **SPAN** switch (SW2) for 2 seconds LED2 will flash. If the SPAN routine is OK, all the LEDs (1 thru 4) will flash. The 0-1 volt output will snap to 0.25 volt. Minor adjusts for ZERO (R48) and SPAN (R44) may be done but the digital ZERO and SPAN will give you better accuracy.

With **RANGE** set to **10.0%** CO₂. Press **RANGE** switch (**SW1**) while measuring the 0 to 1 volt output for 0.500 volt = 10% (see chart below). To move the **RANGE**, press and hold the **RANGE** switch while measuring the 0-1 volt output and use the **UP** switch (**SW4**) or the **DOWN** switch (**SW2**) to move it up or down. The **RANGE** defines the 0-1 volt and 4-20 mA outputs as shown below with the **10%** example:

VALTRONICS 10% & 1 volt linear full scale revised on 10/4/00

Gas in %	Output in volts	±5 of Reading		4-20 mA output	±5 of Reading		4-20 mA across 250Ω in volts
		Max.	Min.		Max.	Min.	
0.00	0.000	0.025	-0.025	4.00	4.40	3.60	1.00
0.20	0.020	0.045	-0.005	4.32	4.72	3.92	1.08
0.40	0.040	0.065	0.015	4.64	5.04	4.24	1.16
0.60	0.060	0.085	0.035	4.96	5.36	4.56	1.24
0.80	0.080	0.105	0.055	5.28	5.68	4.88	1.32
1.00	0.100	0.125	0.075	5.60	6.00	5.20	1.40
1.20	0.120	0.145	0.095	5.92	6.32	5.52	1.48
1.40	0.140	0.165	0.115	6.24	6.64	5.84	1.56
1.60	0.160	0.185	0.135	6.56	6.96	6.16	1.64
1.80	0.180	0.205	0.155	6.88	7.28	6.48	1.72
2.00	0.200	0.225	0.175	7.20	7.60	6.80	1.80
2.20	0.220	0.245	0.195	7.52	7.92	7.12	1.88
2.40	0.240	0.265	0.215	7.84	8.24	7.44	1.96
2.60	0.260	0.285	0.235	8.16	8.56	7.76	2.04
2.80	0.280	0.305	0.255	8.48	8.88	8.08	2.12
3.00	0.300	0.325	0.275	8.80	9.20	8.40	2.20
3.20	0.320	0.345	0.295	9.12	9.52	8.72	2.28
3.40	0.340	0.365	0.315	9.44	9.84	9.04	2.36
3.60	0.360	0.385	0.335	9.76	10.16	9.36	2.44
3.80	0.380	0.405	0.355	10.08	10.48	9.68	2.52
4.00	0.400	0.425	0.375	10.40	10.80	10.00	2.60
4.20	0.420	0.445	0.395	10.72	11.12	10.32	2.68
4.40	0.440	0.465	0.415	11.04	11.44	10.64	2.76
4.60	0.460	0.485	0.435	11.36	11.76	10.96	2.84
4.80	0.480	0.505	0.455	11.68	12.08	11.28	2.92
5.00	0.500	0.525	0.475	12.00	12.40	11.60	3.00
5.20	0.520	0.545	0.495	12.32	12.72	11.92	3.08
5.40	0.540	0.565	0.515	12.64	13.04	12.24	3.16
5.60	0.560	0.585	0.535	12.96	13.36	12.56	3.24
5.80	0.580	0.605	0.555	13.28	13.68	12.88	3.32
6.00	0.600	0.625	0.575	13.60	14.00	13.20	3.40
6.20	0.620	0.651	0.589	13.92	14.42	13.42	3.48
6.40	0.640	0.672	0.608	14.24	14.75	13.73	3.56
6.60	0.660	0.693	0.627	14.56	15.09	14.03	3.64
6.80	0.680	0.714	0.646	14.88	15.42	14.34	3.72
7.00	0.700	0.735	0.665	15.20	15.76	14.64	3.80
7.20	0.720	0.756	0.684	15.52	16.10	14.94	3.88
7.40	0.740	0.777	0.703	15.84	16.43	15.25	3.96
7.60	0.760	0.798	0.722	16.16	16.77	15.55	4.04
7.80	0.780	0.819	0.741	16.48	17.10	15.86	4.12
8.00	0.800	0.840	0.760	16.80	17.44	16.16	4.20
8.20	0.820	0.861	0.779	17.12	17.78	16.46	4.28
8.40	0.840	0.882	0.798	17.44	18.11	16.77	4.36
8.60	0.860	0.903	0.817	17.76	18.45	17.07	4.44
8.80	0.880	0.924	0.836	18.08	18.78	17.38	4.52
9.00	0.900	0.945	0.855	18.40	19.12	17.68	4.60
9.20	0.920	0.966	0.874	18.72	19.46	17.98	4.68
9.40	0.940	0.987	0.893	19.04	19.79	18.29	4.76
9.60	0.960	1.008	0.912	19.36	20.13	18.59	4.84
9.80	0.980	1.029	0.931	19.68	20.46	18.90	4.92
10.00	1.000	1.050	0.950	20.00	20.80	19.20	5.00

Accuracy = ±5% of reading from 5 to 10% gas and ±0.25% gas from 0 to 5% gas