



Model 2008SDH 20% CO₂ 2008SDH-P 20%

(low profile terminal block and 90° hose barbs on gas cell option)

Specification: 2008SDH 20% CO₂

Method: N.D. I. R. (Non-dispersive Infra-red) Sample draw type gas sampling
(see VTI **Application Note A7** - Recommended Gas Conditioning)

Gas sample hose barbs: Designed for 1/8 inch I.D. tubing and **flow rates** between 0.05 and 0.3 liter/minute
see Application Note A24 about gas calibration.

Gas: Carbon Dioxide (CO₂)

Range: 0-20% CO₂

Accuracy: ± 5% of reading (±0.5% CO₂ from 0 to 10% CO₂) - see scale data

Repeatability: ± 1% of full scale (challenge with same gas sample and assure zero)

External Power Source: 12 Volts D.C. @ 0.6 amp. max.(11.0 to 16.0 VDC absolute min./max.)

Power Consumption: less than 3 watts @ 12.0 VDC (2.4 watts typical, 7.2 watts peak at 12.0 V)

Output Signals: Std. output connector is a Phoenix 5 pin male with mating terminal block, see option below

Voltage: 0 to 1 volt = 0 to 20% CO₂ (linear scale data attached)

Current Loop: 4 to 20 mA = 0 to 20% CO₂ (linear scale data attached) 300Ω max loop R

Zero Drift at Constant Temperature: Less than 2% of full scale per 24 hours (random not cumulative)

Zero Noise at Constant Temperature: .. Less than 10 mV peak to peak, measured on V out during any 20 second period

Zero Drift due to Ambient Temp: Less than 0.5% of full scale per degree Centigrade

Operating Temperature Range: 0 to 50°C (32° to 122°F) See **Application Note A12**

Storage Temperature Range: -40 to +70°C (-40 to +158°F)

Operating Humidity Range: 5 to 95% RH non-condensing See **Application Note A30**

Weight: Less than 0.5 pounds (0.23 kilograms)

External Dimensions: PCB Card: 3.9" x 5" x 1.5" dimensions are in inches
..... see diagram on page 2 for mounting



Gas calibration should be done every 6 months. Flow nitrogen at about 0.3 to 1 liter/min through the cell and adjust ZERO for a 0-1 volt output of 0.00 volt Check the 4-20 mA output for 4.0±0.4 mA. Adjust 4mA if necessary. Flow 10.0±0.2% CO₂ through cell and adjust SPAN for 0.50 volt and check current loop for an output of 12.0±0.4 mA. Adjust 20 mA if necessary.

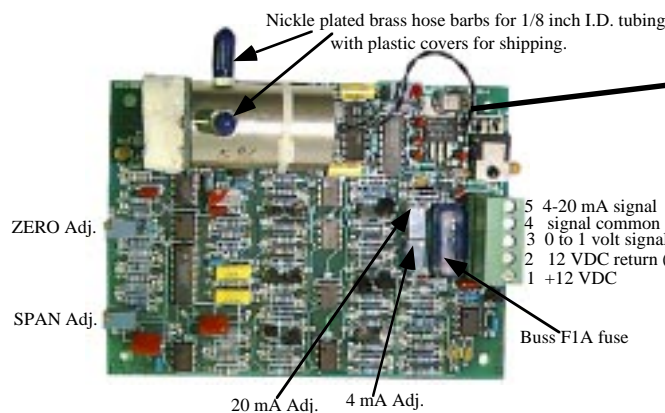

IR Source (emitter) leads. With power off an ohmmeter should read about 3 to 4 ohms cold.

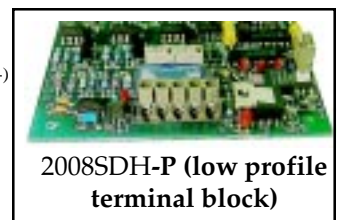

Note: Flow rate through the gas cell should not exceed 1 liter per minute to assure that the gas cell is not pressurized. A pressure in the gas cell above atmospheric pressure will result in a SPAN error (gas law). Gas calibration should be done every 6 months, especially ZERO adjust using ZERO gas (nitrogen). See **Application Note A7** for information about gas conditioning and parts for filtering the gas and preventing water droplets from entering the gas cell. See **Application Note A50** for PC board troubleshooting.



Adjustable 90° hose barb option on gas cell for lower profile

VALTRONICS 5% & 1 volt full scale linear - chart revised on 3-

Gas in %	Output in volts	±5% of reading		4-20 mA output	±5% of reading		4-20 mA across 250Ω in volts
		Max.	Min.		Max.	Min.	
0.00	0.000	0.025	-0.025	4.00	4.40	3.60	1.00
0.40	0.020	0.045	-0.005	4.32	4.72	3.92	1.08
0.80	0.040	0.065	0.015	4.64	5.04	4.24	1.16
1.20	0.060	0.085	0.035	4.96	5.36	4.56	1.24
1.60	0.080	0.105	0.055	5.28	5.68	4.88	1.32
2.00	0.100	0.125	0.075	5.60	6.00	5.20	1.40
2.40	0.120	0.145	0.095	5.92	6.32	5.52	1.48
2.80	0.140	0.165	0.115	6.24	6.64	5.84	1.56
3.20	0.160	0.185	0.135	6.56	6.96	6.16	1.64
3.60	0.180	0.205	0.155	6.88	7.28	6.48	1.72
4.00	0.200	0.225	0.175	7.20	7.60	6.80	1.80
4.40	0.220	0.245	0.195	7.52	7.92	7.12	1.88
4.80	0.240	0.265	0.215	7.84	8.24	7.44	1.96
5.20	0.260	0.285	0.235	8.16	8.56	7.76	2.04
5.60	0.280	0.305	0.255	8.48	8.88	8.08	2.12
6.00	0.300	0.325	0.275	8.80	9.20	8.40	2.20
6.40	0.320	0.345	0.295	9.12	9.52	8.72	2.28
6.80	0.340	0.365	0.315	9.44	9.84	9.04	2.36
7.20	0.360	0.385	0.335	9.76	10.16	9.36	2.44
7.60	0.380	0.405	0.355	10.08	10.48	9.68	2.52
8.00	0.400	0.425	0.375	10.40	10.80	10.00	2.60
8.40	0.420	0.445	0.395	10.72	11.12	10.32	2.68
8.80	0.440	0.465	0.415	11.04	11.44	10.64	2.76
9.20	0.460	0.485	0.435	11.36	11.76	10.96	2.84
9.60	0.480	0.505	0.455	11.68	12.08	11.28	2.92
10.00	0.500	0.525	0.475	12.00	12.40	11.60	3.00
10.40	0.520	0.546	0.494	12.32	12.74	11.90	3.08
10.80	0.540	0.567	0.513	12.64	13.07	12.21	3.16
11.20	0.560	0.588	0.532	12.96	13.41	12.51	3.24
11.60	0.580	0.609	0.551	13.28	13.74	12.82	3.32
12.00	0.600	0.630	0.570	13.60	14.08	13.12	3.40
12.40	0.620	0.651	0.589	13.92	14.42	13.42	3.48
12.80	0.640	0.672	0.608	14.24	14.75	13.73	3.56
13.20	0.660	0.693	0.627	14.56	15.09	14.03	3.64
13.60	0.680	0.714	0.646	14.88	15.42	14.34	3.72
14.00	0.700	0.735	0.665	15.20	15.76	14.64	3.80
14.40	0.720	0.756	0.684	15.52	16.10	14.94	3.88
14.80	0.740	0.777	0.703	15.84	16.43	15.25	3.96
15.20	0.760	0.798	0.722	16.16	16.77	15.55	4.04
15.60	0.780	0.819	0.741	16.48	17.10	15.86	4.12
16.00	0.800	0.840	0.760	16.80	17.44	16.16	4.20
16.40	0.820	0.861	0.779	17.12	17.78	16.46	4.28
16.80	0.840	0.882	0.798	17.44	18.11	16.77	4.36
17.20	0.860	0.903	0.817	17.76	18.45	17.07	4.44
17.60	0.880	0.924	0.836	18.08	18.78	17.37	4.52
18.00	0.900	0.945	0.855	18.40	19.12	17.68	4.60
18.40	0.920	0.966	0.874	18.72	19.46	17.98	4.68
18.80	0.940	0.987	0.893	19.04	19.79	18.29	4.76
19.20	0.960	1.008	0.912	19.36	20.13	18.59	4.84
19.60	0.980	1.029	0.931	19.68	20.46	18.90	4.92
20.00	1.000	1.050	0.950	20.00	20.80	19.20	5.00

Accuracy = ±5% of reading from 10% CO2 to 20% and ±0.5% CO2 from 0 to 10% CO2

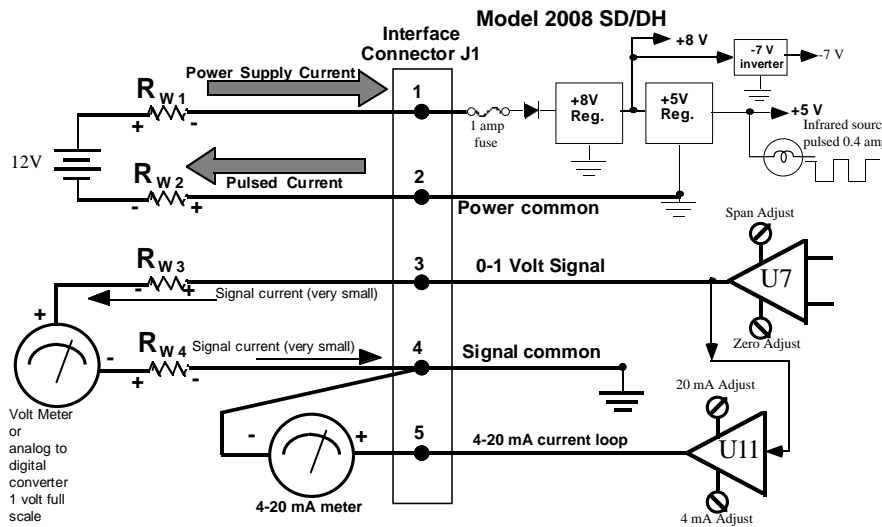

• The pulsating power supply return current will take the path of least resistance. If the wire from pin# 2 is large and short it will travel through it and not in the signal path which would introduce an offset and noise. The SIGNAL COMMON must have a separate wire for signal current to flow through. There must be a minimum of four (4) wires. A three (3) wire connection where one wire is used for both power supply and signal common will **not work** even with the current loop.

