



Model 2008DHL 1% (10,000 ppm) CO₂

VALTRONICS & 1 volt full scale Accuracy = ±0.025% CO₂ from 0 to 0.5% CO₂ and ±5% of reading from 0.5 to 1% CO₂

Gas in %	Output in volts	±0.025% CO ₂		4-20 mA output	±0.025% CO ₂		Gas in %	Output in volts	±5% of Reading		4-20 mA output	±5% of Reading	
		Max	Min		Max	Min			Max	Min		Max	Min
0.00	0.000	0.025	-0.025	4.00	4.40	3.60	0.51	0.510	0.536	0.485	12.16	12.57	11.75
0.01	0.010	0.035	-0.015	4.16	4.56	3.76	0.52	0.520	0.546	0.494	12.32	12.74	11.90
0.02	0.020	0.045	-0.005	4.32	4.72	3.92	0.53	0.530	0.557	0.504	12.48	12.90	12.06
0.03	0.030	0.055	0.005	4.48	4.88	4.08	0.54	0.540	0.567	0.513	12.64	13.07	12.21
0.04	0.040	0.065	0.015	4.64	5.04	4.24	0.55	0.550	0.578	0.523	12.80	13.24	12.36
0.05	0.050	0.075	0.025	4.80	5.20	4.40	0.56	0.560	0.588	0.532	12.96	13.41	12.51
0.06	0.060	0.085	0.035	4.96	5.36	4.56	0.57	0.570	0.599	0.542	13.12	13.58	12.66
0.07	0.070	0.095	0.045	5.12	5.52	4.72	0.58	0.580	0.609	0.551	13.28	13.74	12.82
0.08	0.080	0.105	0.055	5.28	5.68	4.88	0.59	0.590	0.620	0.561	13.44	13.91	12.97
0.09	0.090	0.115	0.065	5.44	5.84	5.04	0.60	0.600	0.630	0.570	13.60	14.08	13.12
0.10	0.100	0.125	0.075	5.60	6.00	5.20	0.61	0.610	0.641	0.580	13.76	14.25	13.27
0.11	0.110	0.135	0.085	5.76	6.16	5.36	0.62	0.620	0.651	0.589	13.92	14.42	13.42
0.12	0.120	0.145	0.095	5.92	6.32	5.52	0.63	0.630	0.662	0.599	14.08	14.58	13.58
0.13	0.130	0.155	0.105	6.08	6.48	5.68	0.64	0.640	0.672	0.608	14.24	14.75	13.73
0.14	0.140	0.165	0.115	6.24	6.64	5.84	0.65	0.650	0.683	0.618	14.40	14.92	13.88
0.15	0.150	0.175	0.125	6.40	6.80	6.00	0.66	0.660	0.693	0.627	14.56	15.09	14.03
0.16	0.160	0.185	0.135	6.56	6.96	6.16	0.67	0.670	0.704	0.637	14.72	15.26	14.18
0.17	0.170	0.195	0.145	6.72	7.12	6.32	0.68	0.680	0.714	0.646	14.88	15.42	14.34
0.18	0.180	0.205	0.155	6.88	7.28	6.48	0.69	0.690	0.725	0.656	15.04	15.59	14.49
0.19	0.190	0.215	0.165	7.04	7.44	6.64	0.70	0.700	0.735	0.665	15.20	15.76	14.64
0.20	0.200	0.225	0.175	7.20	7.60	6.80	0.71	0.710	0.746	0.675	15.36	15.93	14.79
0.21	0.210	0.235	0.185	7.36	7.76	6.96	0.72	0.720	0.756	0.684	15.52	16.10	14.94
0.22	0.220	0.245	0.195	7.52	7.92	7.12	0.73	0.730	0.767	0.694	15.68	16.26	15.10
0.23	0.230	0.255	0.205	7.68	8.08	7.28	0.74	0.740	0.777	0.703	15.84	16.43	15.25
0.24	0.240	0.265	0.215	7.84	8.24	7.44	0.75	0.750	0.788	0.713	16.00	16.60	15.40
0.25	0.250	0.275	0.225	8.00	8.40	7.60	0.76	0.760	0.798	0.722	16.16	16.77	15.55
0.26	0.260	0.285	0.235	8.16	8.56	7.76	0.77	0.770	0.809	0.732	16.32	16.94	15.70
0.27	0.270	0.295	0.245	8.32	8.72	7.92	0.78	0.780	0.819	0.741	16.48	17.10	15.86
0.28	0.280	0.305	0.255	8.48	8.88	8.08	0.79	0.790	0.830	0.751	16.64	17.27	16.01
0.29	0.290	0.315	0.265	8.64	9.04	8.24	0.80	0.800	0.840	0.760	16.80	17.44	16.16
0.30	0.300	0.325	0.275	8.80	9.20	8.40	0.81	0.810	0.851	0.770	16.96	17.61	16.31
0.31	0.310	0.335	0.285	8.96	9.36	8.56	0.82	0.820	0.861	0.779	17.12	17.78	16.46
0.32	0.320	0.345	0.295	9.12	9.52	8.72	0.83	0.830	0.872	0.789	17.28	17.94	16.62
0.33	0.330	0.355	0.305	9.28	9.68	8.88	0.84	0.840	0.882	0.798	17.44	18.11	16.77
0.34	0.340	0.365	0.315	9.44	9.84	9.04	0.85	0.850	0.893	0.808	17.60	18.28	16.92
0.35	0.350	0.375	0.325	9.60	10.00	9.20	0.86	0.860	0.903	0.817	17.76	18.45	17.07
0.36	0.360	0.385	0.335	9.76	10.16	9.36	0.87	0.870	0.914	0.827	17.92	18.62	17.22
0.37	0.370	0.395	0.345	9.92	10.32	9.52	0.88	0.880	0.924	0.836	18.08	18.78	17.38
0.38	0.380	0.405	0.355	10.08	10.48	9.68	0.89	0.890	0.935	0.846	18.24	18.95	17.53
0.39	0.390	0.415	0.365	10.24	10.64	9.84	0.90	0.900	0.945	0.855	18.40	19.12	17.68
0.40	0.400	0.425	0.375	10.40	10.80	10.00	0.91	0.910	0.956	0.865	18.56	19.29	17.83
0.41	0.410	0.435	0.385	10.56	10.96	10.16	0.92	0.920	0.966	0.874	18.72	19.46	17.98
0.42	0.420	0.445	0.395	10.72	11.12	10.32	0.93	0.930	0.977	0.884	18.88	19.62	18.14
0.43	0.430	0.455	0.405	10.88	11.28	10.48	0.94	0.940	0.987	0.893	19.04	19.79	18.29
0.44	0.440	0.465	0.415	11.04	11.44	10.64	0.95	0.950	0.998	0.903	19.20	19.96	18.44
0.45	0.450	0.475	0.425	11.20	11.60	10.80	0.96	0.960	1.008	0.912	19.36	20.13	18.59
0.46	0.460	0.485	0.435	11.36	11.76	10.96	0.97	0.970	1.019	0.922	19.52	20.30	18.74
0.47	0.470	0.495	0.445	11.52	11.92	11.12	0.98	0.980	1.029	0.931	19.68	20.46	18.90
0.48	0.480	0.505	0.455	11.68	12.08	11.28	0.99	0.990	1.040	0.941	19.84	20.63	19.05
0.49	0.490	0.515	0.465	11.84	12.24	11.44	1.00	1.000	1.050	0.950	20.00	20.80	19.20
0.50	0.500	0.525	0.475	12.00	12.40	11.60							

Revised on 2-2-95

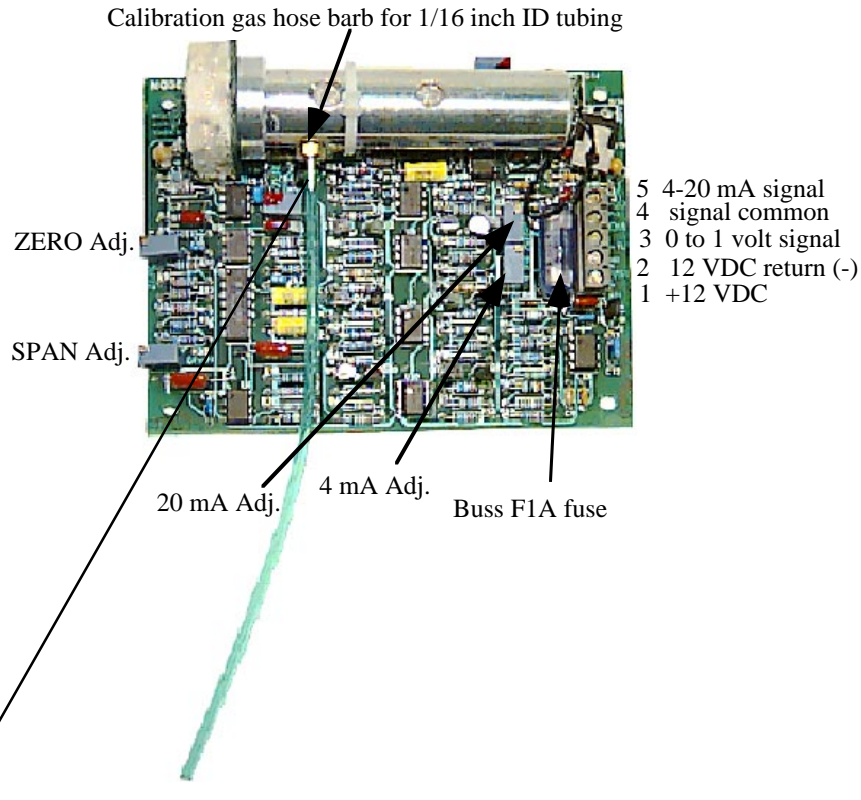

The gas calibration hose barb (for 1/16 inch ID tubing) should be used every six to twelve months to adjust the ZERO and SPAN. Fresh air with about 400 ppm (0.04%) CO₂ would be OK as a zero gas and to adjust the ZERO potentiometer. A tank of dry nitrogen would be better because you would be sure that you do not pump any oil or particles into the gas cell. This calibration port should not be used as a gas sample port unless you are sure that all water droplets, oil, and dust particles are removed from that sample. The flow rate should not exceed 300 ml/min to avoid pressurizing the gas cell. Certified 0.5±0.01% CO₂ should be used to adjust the SPAN potentiometer. A span gas concentration near mid-scale (0.5%) will give better accuracy near that point. See Application Note A25 or A40 for more detailed calibration instructions. Valtronics will supply complete gas calibration kits upon request.

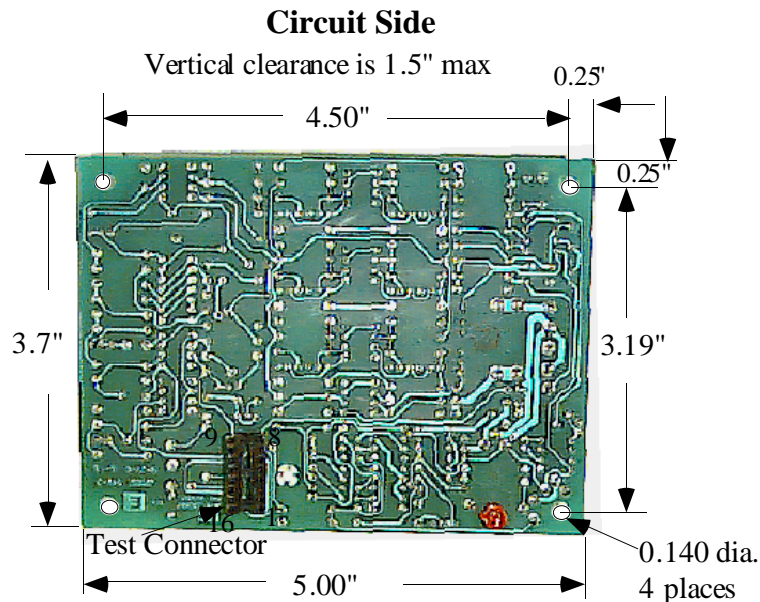

The following diagram is a symbolic representation of the interface terminal block TB1 (J1 on some 2008 units) and connections made to it. It shows why it is important to use a minimum of four (4) wires to operate it. If you use the 4 to 20 mA current loop output (pins 5 and 4), please remember that it will not drive more than about 300 ohms total resistance in that current loop. This is because the current loop's amplifier is powered from 8 volts DC. The full scale output of 20 mA multiplied by the loop resistance of 300 ohms results in an output voltage of 6.0 volts. Greater than 6 volts may not be reliably produced given worst case component tolerances and temperature conditions.

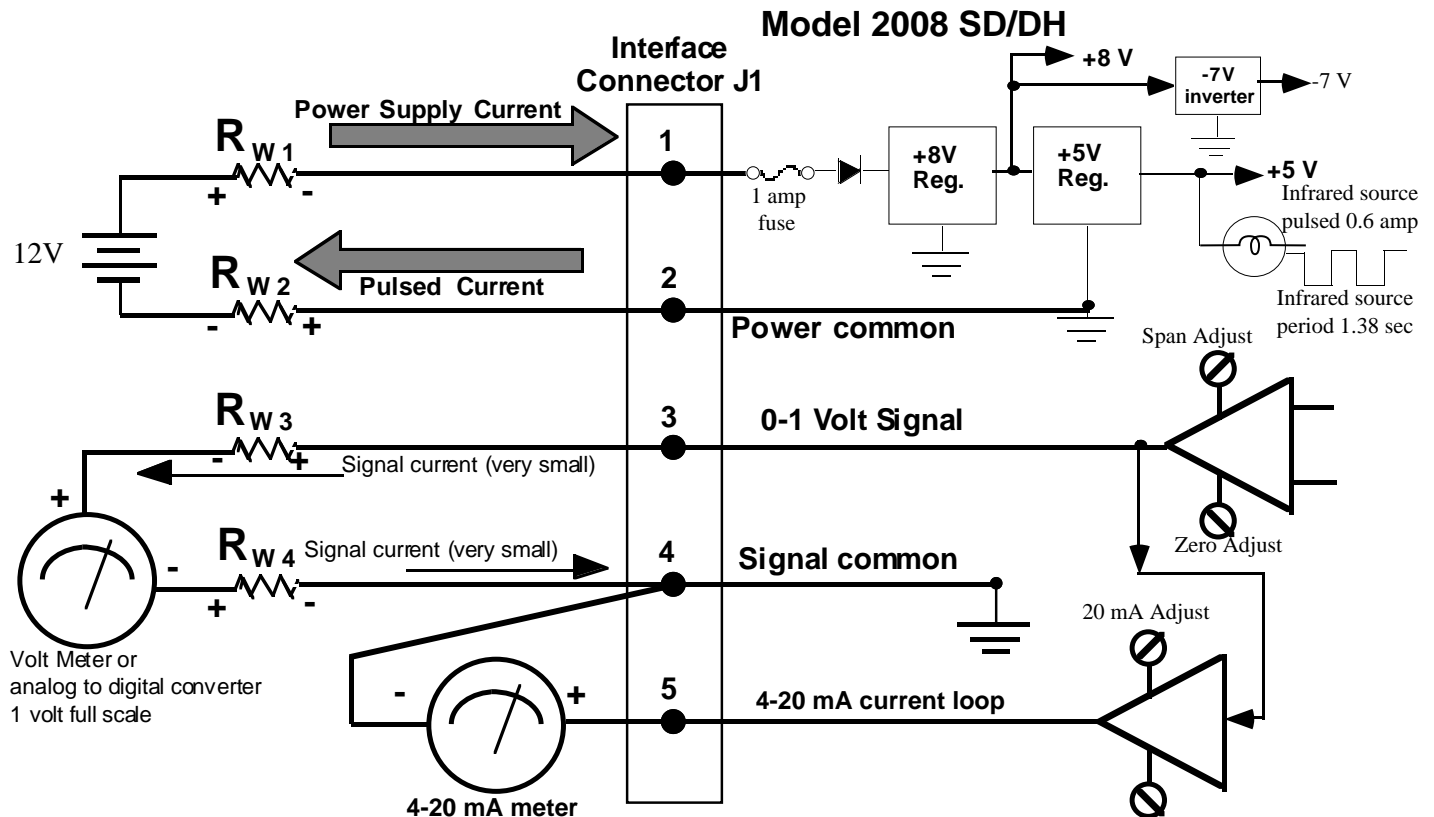

The pulsating power supply return current will take the path of least resistance. If the wire from pin# 2 is of a large diameter and short, the current will travel through it and not in the signal path which would introduce noise. The SIGNAL COMMON must have a separate wire for signal current to flow through. There must be a minimum of four (4) wires. A three (3) wire connection where one wire is used for both power supply and signal common will not work well even with the current loop. The current loop will compensate for wire resistance but it takes a few seconds to do that since we filter its response to about 10 seconds. The voltage produced across the wire resistance R_w , (source current of about 0.6 amp peak times the wire resistance) every 1.38 seconds will appear as noise.

Units are delivered gas calibrated at an elevation of about 700 ft. and 23°C (see Application Note A12). We will custom calibrate for special altitudes upon request. Calibration adjustments made to the ZERO potentiometer R11 and SPAN potentiometer R22 should only be done using certified (at least $\pm 2\%$ of reading) calibration gas. Please refer to your manual and **VALTRONICS** Application Note A25 or A40 for detailed gas calibration instructions. Adjustments made to the 4 mA potentiometer R64 and the 20 mA potentiometer R63 should only be done after R11 and R22 are properly adjusted.