

The **Infra-Red detector** is ZERO temperature compensated. With ZERO (N_2) gas in the cell, the ideal peak to peak output of the pre-amplifier should not change as temperature changes. The reality is that the detector gets more sensitive as temperature goes down. The peak to peak signal out of the detector increases as temperature decreases. To compensate for this we change the gain of the pre-amp using an NTC thermistor.

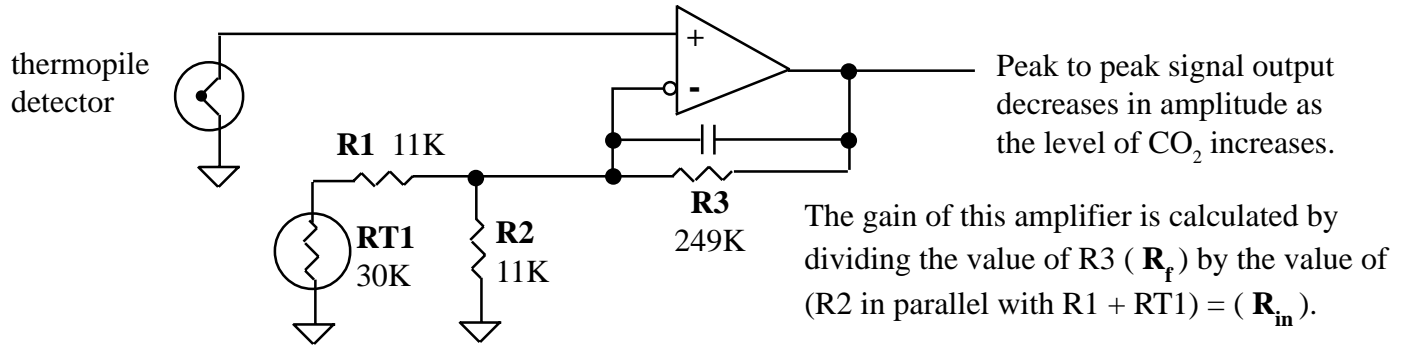

If the 0 to 1 volt output goes **up-scale** as **temperature increases** with nitrogen in the gas cell then the detector is **under compensated**. The gain of the preamp needs to increase more as temperature increases to keep the peak to peak preamp signal from decreasing too much as temperature increases. You would do this by decreasing the value of R_{in} .

Pyro-electric detector sensors like the 2008SDH and the 6289 family are compensated by using a linear temperature (AD592) transducer in the ZERO restorer to change the gain as a function of temperature. The principle is the same however.

Our new **digital NDIR** sensors (SPI) are temperature compensated in software for both ZERO and SPAN.

See page two for the theory of CO_2 absorption in the **Infra-Red** spectra. The **Infra-Red** source (emitter) pulses broad band **IR** energy into the gas cell. The **IR** Band Pass Filter is designed to pass just those wavelengths that are absorbed by CO_2 on to the detector. Compounds like hydrocarbons (methane, butane, propane, hexane, methanol, ethanol, etc) will not interfere since they absorb in the 3000 to 3100 wave number region and CO_2 absorbs in the 2400 to 2800 wave number region.

You may see a small interference (about 50 ppm) from high concentrations of water vapor if your full scale is down in the 2000 ppm (0.2%) CO_2 region. Significant interference will be seen from percent concentrations of carbon monoxide (CO) and percent concentrations of nitrous oxide (N_2O).

See **Application Note A67** for gas conditioning information. Dust particles and water droplets will definitely cause serious problems inside a flow through gas cell. A **hydrophobic filter** should be used as a minimum immediately in front of the gas inlet where gas is **pushed** into the cell. **DO NOT draw** a gas sample through a flow through gas cell because the cell is not hermetically sealed and the gas sample may be diluted. The gas cell should be under a small positive pressure with respect to ambient atmospheric pressure. See **Application Note A12** for information about the effects of temperature and pressure (gas law). The exhaust hose barb on a flow through gas cell should have minimal flow restriction (short large tube) to avoid excessive gas pressure in the cell.

NDIR Theory of Operation

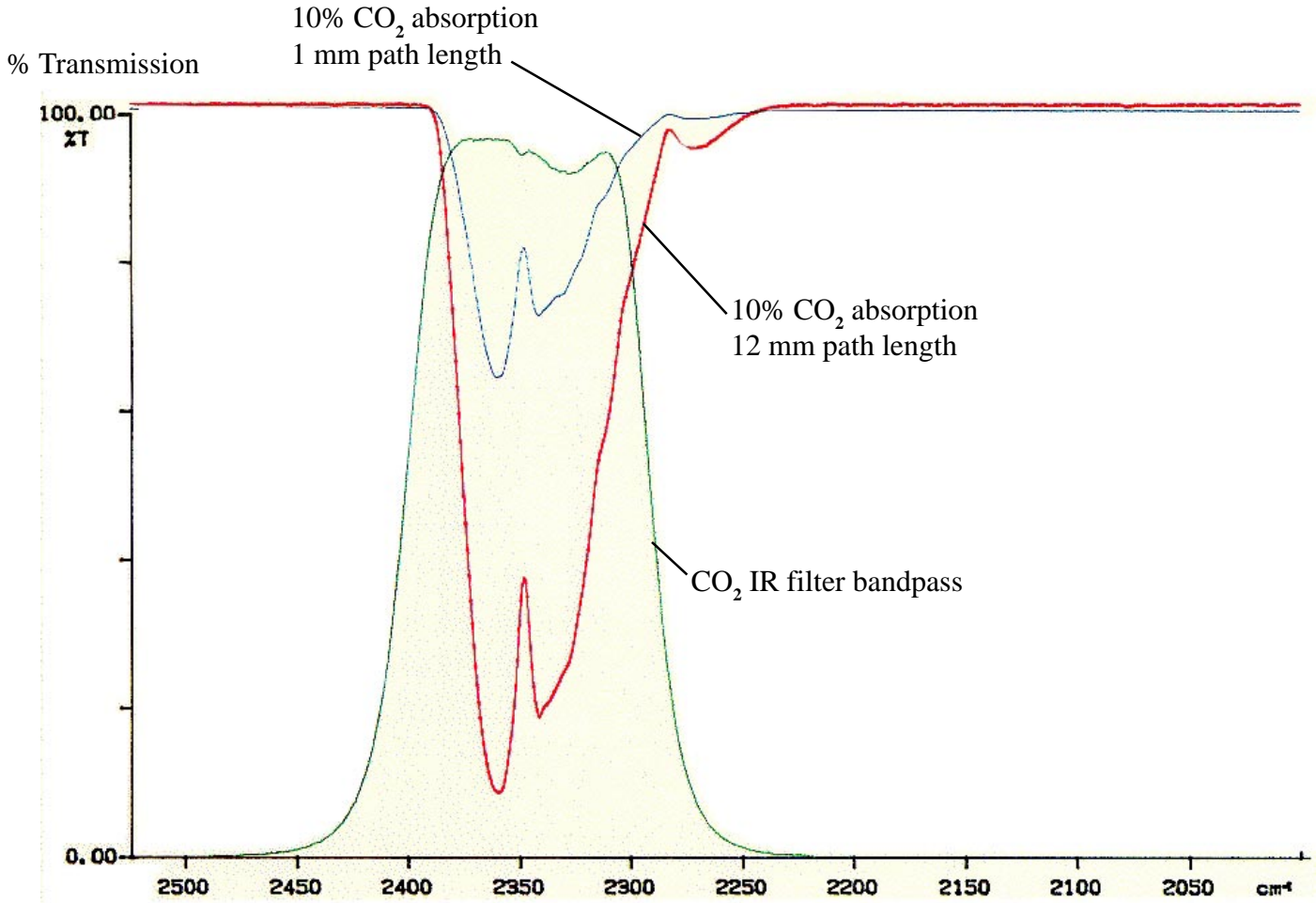

The reciprocal of the wavelength in centimeters
(the center wavelength is about 4.24 μM)

