



Application Note A69 - ZERO Temp. Comp. Thermopile Trouble Shooting & Theory of Operation

The **thermopile detector** is ZERO temperature compensated by an operational amplifier with its' gain controlled by a **30K @25°C NTC thermistor** (see table below). The Model **2015BMC-F** is an example of a thermopile detector with NTC thermistor temperature compensation. With ZERO (N₂)gas in the cell, the ideal peak to peak output of the pre-amplifier should not change as temperature changes. The reality is that the detector's responsivity (about **-0.4%/°C**) decreases as temperature increases. To compensate for this we change the gain of the pre-amp by using a 30K at 25°C thermistor in the preamp. At 0°C the thermistor is about 95K instead of 30K at 25°C and at 50°C it is about 11K. With the standard values of R3 = 249K, R1 = 11K and R2 = 11K, the thermistor decreases the gain of the preamp from about **28** at 25°C to about **25** at **0°C**. It increases the gain to about **33** at **50°C**. The thermistor has a ±5% tolerance. See the chart below for the effect of these tolerances.

Thermopile Detector:

Its peak to peak output decreases as temperature increases by about **-0.4% per °C** with nitrogen in the gas cell. See page 4 for theory of operation & block diagram.

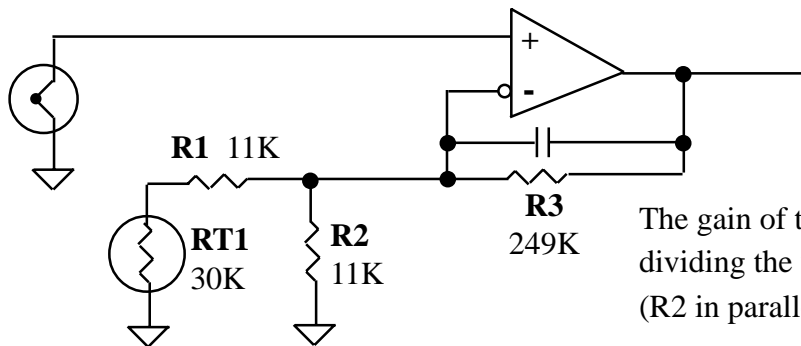

Peak to peak signal output **decreases** in amplitude as the level of CO₂ increases.

The gain of this amplifier is calculated by dividing the value of R3 (R_f) by the value of (R2 in parallel with R1 + RT1) = (R_{in}).

Gain = Rf/Rin	Rf= 249K	Rf MAX	Rf MIN	11000	11110	10890
DALE®Thermistor: 8C3002-5		251490	246510	11000	11110	10890
curve = 8		Rt MAX@ 25°C	Rt MIN@ 25°C			
30K±5% @25°C		31500	28500			
Temp °C	Rt/R25°C			Minimum Gain	Maximum Gain	Average Gain
0	3.166	99729	90231	24.0	25.6	24.8
5	2.481	78152	70709	24.5	26.2	25.3
10	1.958	61677	55803	25.0	26.9	25.9
15	1.556	49014	44346	25.6	27.6	26.6
20	1.243	39155	35426	26.2	28.5	27.4
25	1.000	31500	28500	27.0	29.5	28.2
30	0.809	25484	23057	27.8	30.5	29.1
35	0.658	20727	18753	28.6	31.6	30.1
40	0.538	16956	15342	29.4	32.7	31.1
45	0.443	13945	12617	30.3	33.8	32.1
50	0.366	11520	10422	31.2	34.9	33.0

This chart shows how the **tolerances** on the components effect the pre-amp gain. The thermistor has a **±5%** tolerance and the resistors have a **±1%** tolerance.

Check the **thermistor** to make sure it is not **shorted** or **open**. If it is **shorted** you will obviously read **0 ohms** across it. If it is **open** you will read the sum of R1 and R2 or about **22K** ohms. It should read about 30K in parallel with 22K or about **12.7K** ohms at **25°C** or **77°F**. At 20°C, per the above chart, it should read about 1.243 times higher resistance or about 37.29 K in parallel with the 22K or about **13.84 K** ohms at **20°C** or **68°F**. °F = 9/5 (°C) + 32 .

If the 0 to 1 volt output goes **up-scale** as **temperature increases** then the detector is **under compensated**. The gain of the preamp needs to increase more as temperature increases to keep the peak to peak preamp signal from decreasing too much as temperature increases. You would do this by decreasing the value of R_{in}. R2 should not be changed. You decrease **R1** to increase the gain and increase compensation. See the charts on Page 2 for the effects of different values of R1 on the gain.

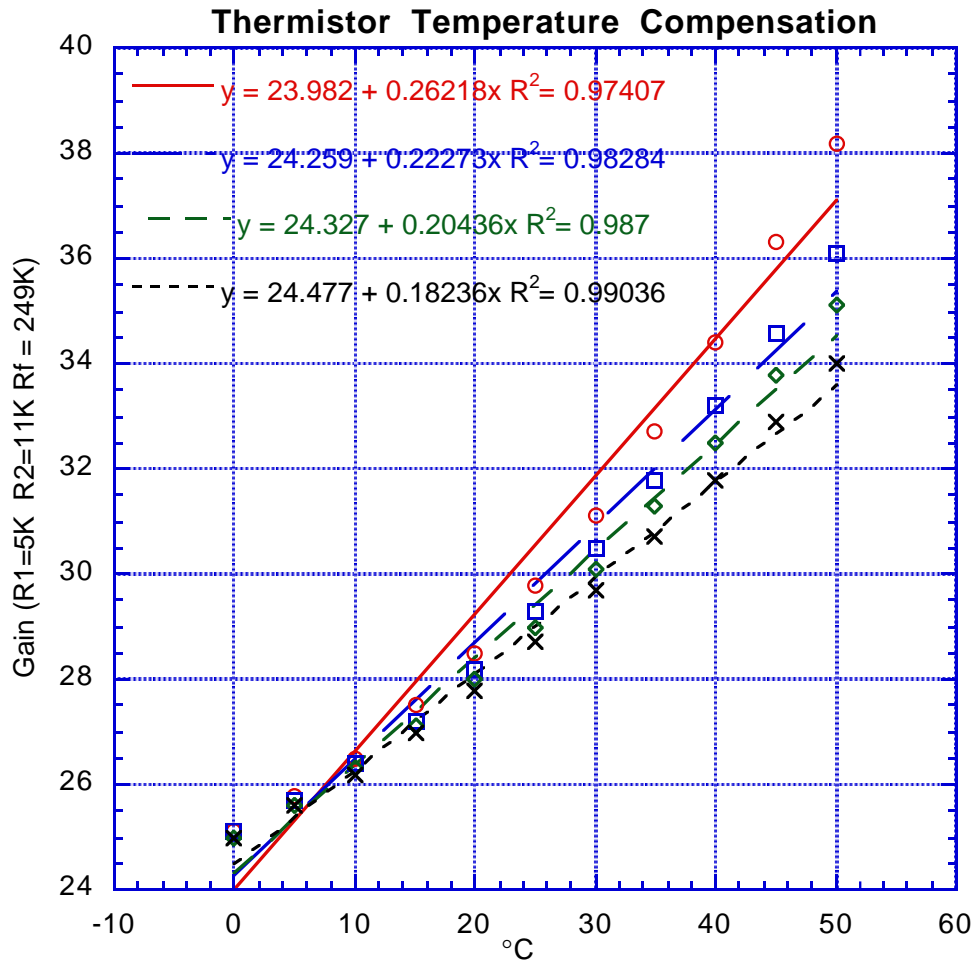
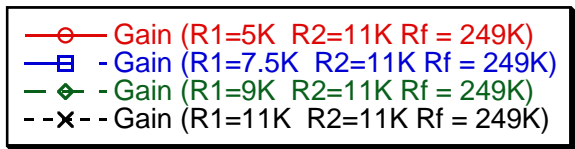

R1 = 5K R2 = 11K RF = 249K

°C	Thermistor	Thermistor +R1	R2//Rt+R1	Gain
0	94980	99980	9910	25.1
5	74430	79430	9662	25.8
10	58740	63740	9381	26.5
15	46680	51680	9070	27.5
20	37290	42290	8729	28.5
25	30000	35000	8370	29.8
30	24270	29270	7995	31.1
35	19740	24740	7614	32.7
40	16149	21149	7236	34.4
45	13281	18281	6868	36.3
50	10971	15971	6514	38.2

R1 = 7.5K R2 = 11K RF = 249K

°C	Thermistor	Thermistor +R1	R2//Rt+R1	Gain
0	94980	102480	9934	25.1
5	74430	81930	9698	25.7
10	58740	66240	9433	26.4
15	46680	54180	9144	27.2
20	37290	44790	8831	28.2
25	30000	37500	8505	29.3
30	24270	31770	8171	30.5
35	19740	27240	7836	31.8
40	16149	23649	7508	33.2
45	13281	20781	7193	34.6
50	10971	18471	6894	36.1

R1 = 9K R2 = 11K RF = 249K

°C	Thermistor	Thermistor +R1	R2//Rt+R1	Gain
0	94980	103980	9948	25.0
5	74430	83430	9719	25.6
10	58740	67740	9463	26.3
15	46680	55680	9185	27.1
20	37290	46290	8888	28.0
25	30000	39000	8580	29.0
30	24270	33270	8267	30.1
35	19740	28740	7955	31.3
40	16149	25149	7653	32.5
45	13281	22281	7364	33.8
50	10971	19971	7093	35.1

R1 = 11K R2 = 11K RF = 249K

°C	Thermistor	Thermistor +R1	R2//Rt+R1	Gain
0	94980	105980	9966	25.0
5	74430	85430	9745	25.6
10	58740	69740	9501	26.2
15	46680	57680	9238	27.0
20	37290	48290	8959	27.8
25	30000	41000	8673	28.7
30	24270	35270	8385	29.7
35	19740	30740	8101	30.7
40	16149	27149	7828	31.8
45	13281	24281	7570	32.9
50	10971	21971	7330	34.0

Application Note A69

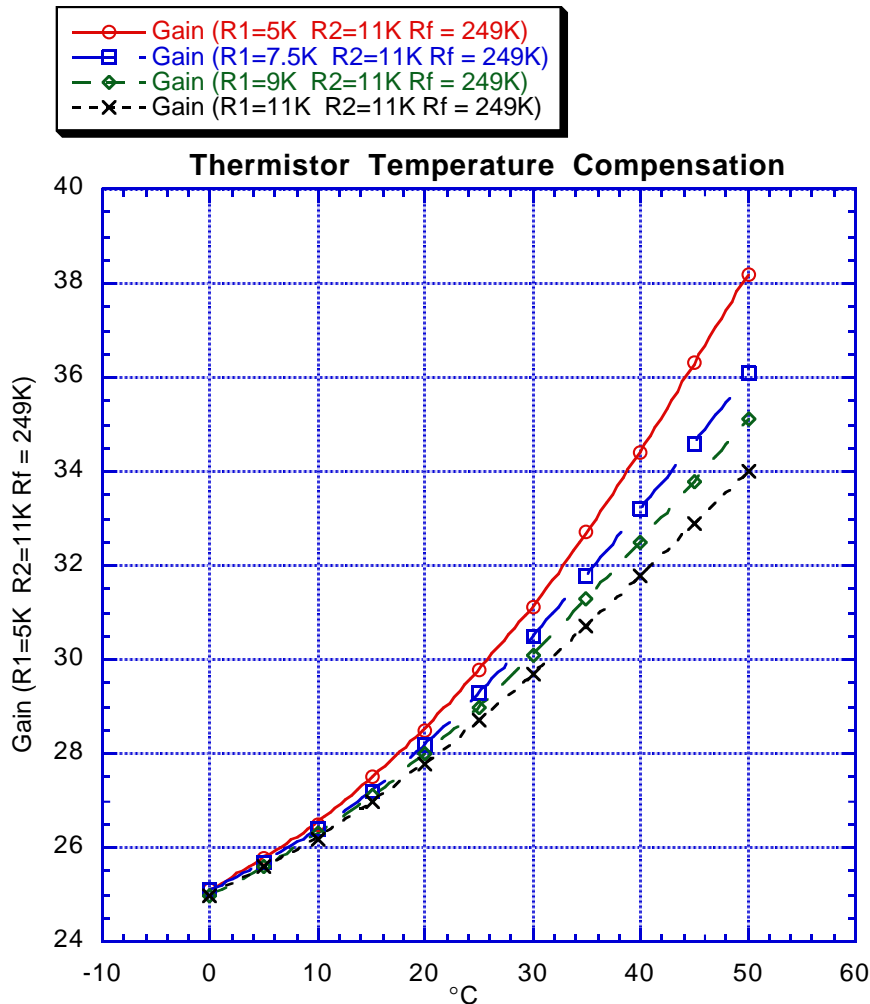

The specification for temperature compensation is that the signal output will not vary more than 0.5% of full scale per degree C. That means a **0 to 1 volt output** should vary less than **5 millivolts** per degree C with ZERO gas in the cell. A **0 to 5 volt output** should vary less than **25 millivolts** per degree C with ZERO gas in the cell. A **0 to 10 volt output** should vary less than **50 millivolts** per degree C with ZERO gas in the cell.

As you can see from the above graph and the graph on page 2, the thermistor compensation is not linear. It compensates more at the higher temperatures. This will cause some units to be slightly **over-compensated** (0 to 1 volt output goes **down-scale** as **temperature increases**) from **25 to 50°C** and more closely compensated from **0 to 25°C**.

Page 4 shows how carbon dioxide absorbs the infra-red energy that the bandpass filter passes through to the detector. The detectors' peak to peak output with nitrogen is at a maximum. The full scale concentration of CO₂ should attenuate this peak to peak level from about 10% to about 40% depending upon the gas cell path length and filter tolerances. This fractional attenuation is converted into the 0 to 1 volt output where 1 volt equals the full scale attenuation and 0 volts equals no attenuation. This is why the peak to peak level needs to be temperature compensated to keep the output relatively stable (less than 0.5% of full scale per °C) as ambient temperature changes.

NDIR Theory of Operation

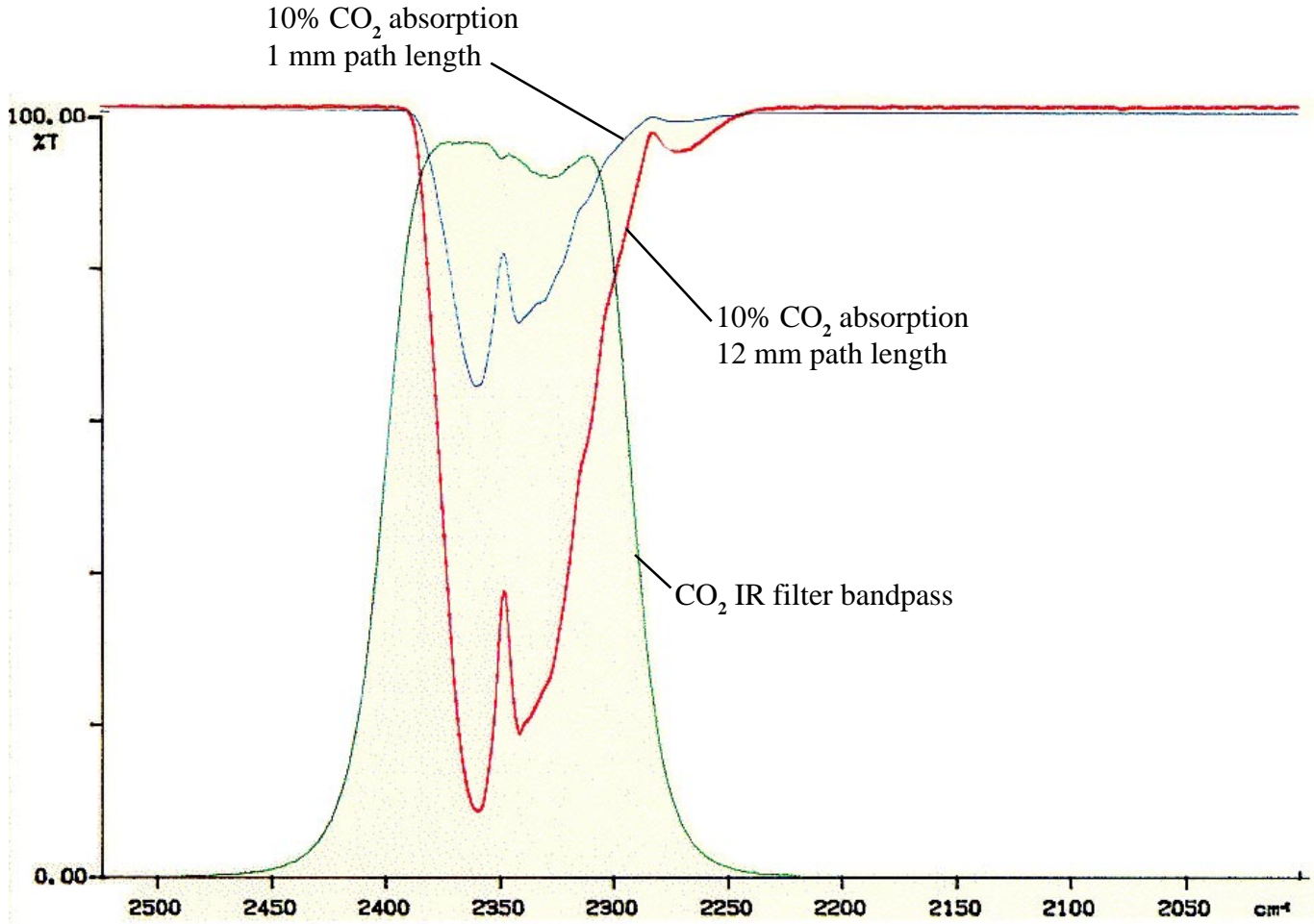

The reciprocal of the wavelength in centimeters know as the **Kayser wave number**

